

PERGOLA Bioclimatică 3×3M

Instrucțiuni de asamblare

Unelte și Echipamente de Protecție Necesare (neincluse)

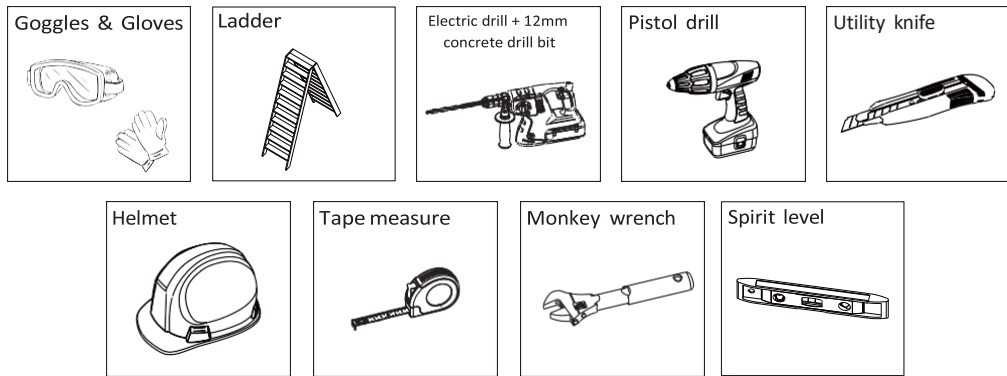

Dimensiuni ale suprafeței de fixare (mm)

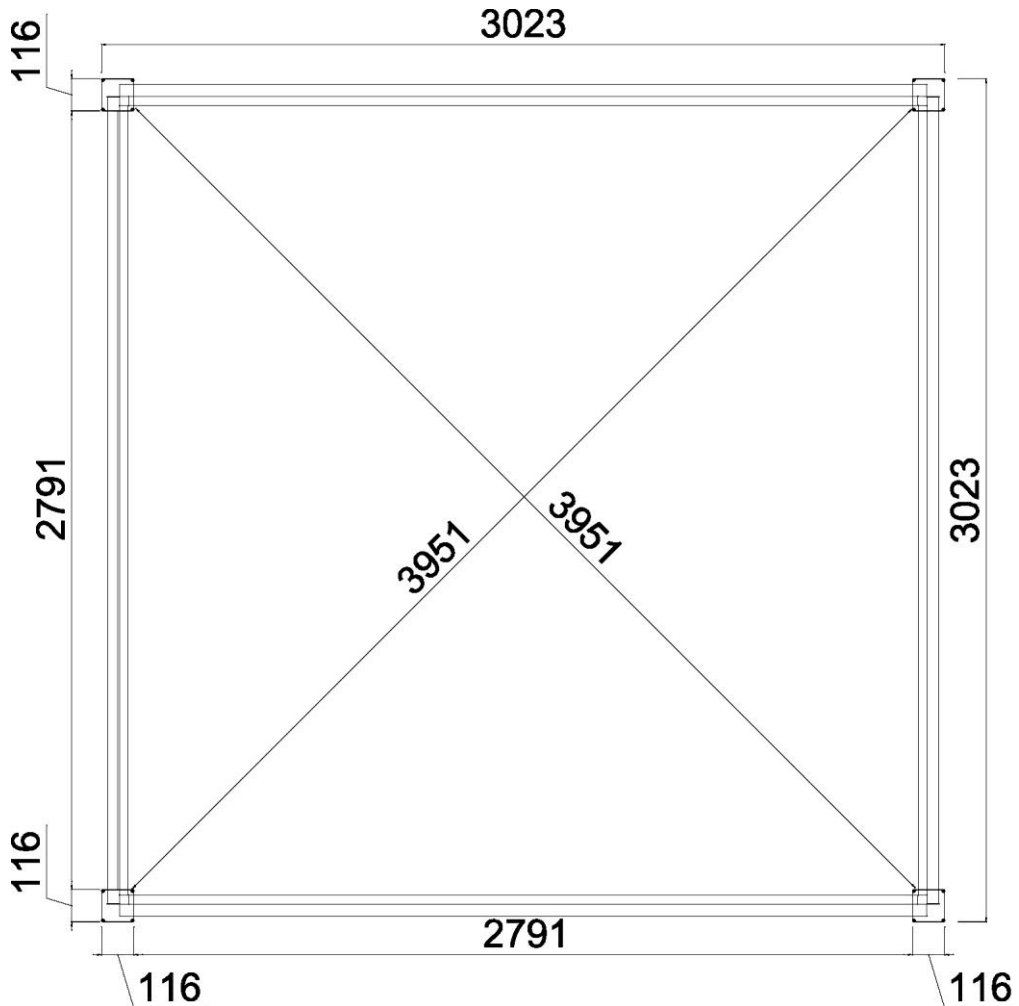

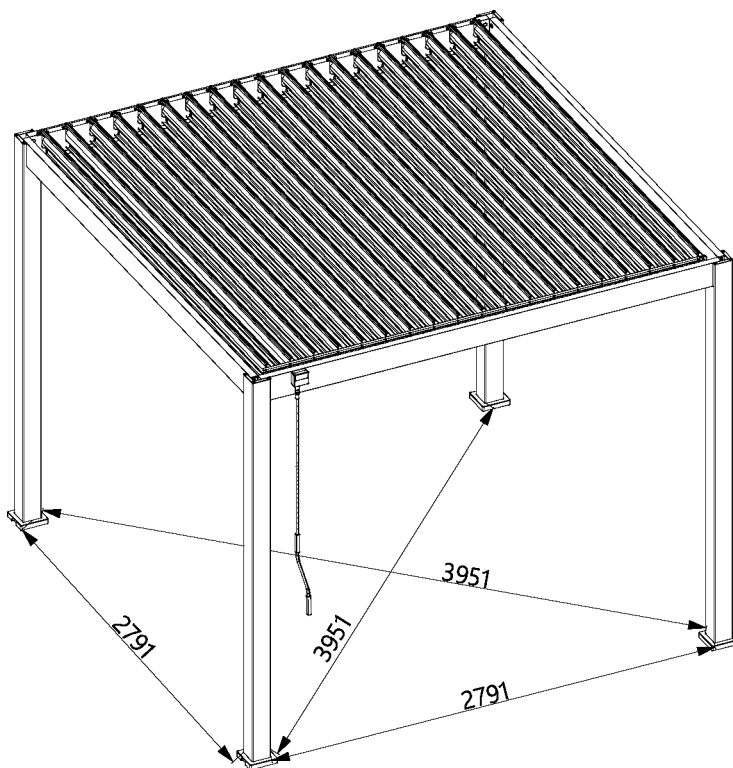

Precauții de utilizare

- Nu utilizați pergola în condiții meteorologice extreme: furtuni, vânturi violente, grindină, zăpadă.
- Pergola este garantată pentru vânturi de până la 60 km/h și o greutate maximă de zăpadă de 30 kg/m².
- În caz de vânt puternic sau zăpadă, se recomandă deschiderea lamelelor.
- Curățați orice zăpadă depusă pe lamele pentru a menține funcționarea optimă.
- Poate rezista la ploi abundente, dar nu este 100% impermeabilă în toate condițiile extreme.
- Nu urcați pe acoperiș sau pe structură – există risc de accidentare.

Sfaturi și instrucțiuni de siguranță

Întreținere:

- Curățați pergola o dată sau de două ori pe an cu apă curată și burete.
- Nu folosiți detergenți sau materiale abrazive.
- Verificați strângerea șuruburilor cel puțin anual.
- Lubrifiați prinderile anual.
- Verificați jgheaburile să nu fie blocate de frunze sau crengi.
- Îndepărtați apa acumulată în jurul stâlpilor (ridicați mascarea bazei).

Asamblare:

- Necesită 2–3 persoane.
- Îndepărtați folia de protecție (aprox. 1 oră).
- Nu lăsați copii în zona de lucru.
- Nu strângeți șuruburile până nu este complet asamblată structura.
- Verificați nivelul structurii pe toate laturile.
- Nu ancorați pergola înainte de finalizarea completă.

! Orice modificare adusă produsului duce la pierderea garanției. !

Amplasare:

- Alegeți o zi fără ploaie și evitați montarea în direcția vântului sau sub copaci.
- Montați pe o fundație plană (placă beton sau 25x25 cm sub fiecare picior).
- Utilizați șuruburi de ancorare cu expansiune.
- Dacă montați lângă o clădire, verificați existența unui sistem de drenaj.

Garanția nu acoperă:

- Uzura normală.
- Pierderea sau ruperea pieselor în timpul despachetării sau montajului.
- Neglijență, vandalism, lovituri, forțe externe, contacte cu materiale abrazive.
- Forță majoră: grindină, vânturi puternice, furtuni, inundații etc.
- Modificări făcute de utilizator.

Reclamațiile trebuie făcute la magazinul sau site-ul de unde a fost achiziționat produsul.

Verificați toate piesele înainte de montaj. Reclamațiile pentru piese lipsă se fac în termen de 10 zile de la livrare.

Nu aruncați ambalajul înainte de a verifica funcționalitatea completă.

Important:

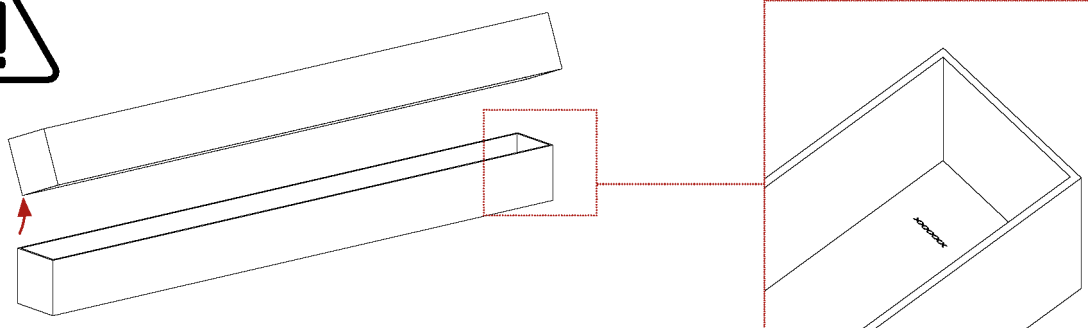

Notați sau fotografiați numărul de urmărire din interiorul cutiei pentru servicii post-vânzare eficiente.















Conținut cutii:











Cutie 1/4



REF	ICON	QTY
AO		4

REF	ICON	QTY
IO		4
JO		4

REF	ICON	QTY
TO	 10×80	16
XO-1	  6×35 4mm	16









REF	ICON	QTY
KO		1
LO		18
LO-1		19
MO		37
QO		16
NO		1
OO		1
RO		16
PO		1

REF	ICON	QTY
SO		38
SO-1		38
WO	 5×6	76
UO	 lock nut	39
UO-2		38
UO-4		38
VO		2
XO	  6×35 4mm	37
YO	 6×45	3

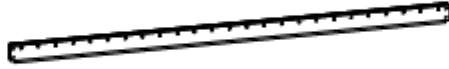
REF	ICON	QTY
ZO-1	 4mm	1
ZO-2	 4mm	1
ZO-3	 6mm	1
ZO-4	 6mm	1

REF	ICON	QTY
ZO-5	 10mm	1
ZO-9	 3mm	1
ZO-10	 3mm	1

Cutia 2/4



REF	ICON	QTY
BO	 	1
BO-1		1
CO		2
DO	 	4
FO	 	2
HO		1

ATTENTION!



Connecting Bar(FO) & Brush Inside!

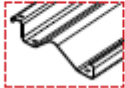

Cutia 3/4

REF	ICON	QTY
GO	 	10

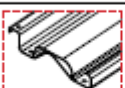
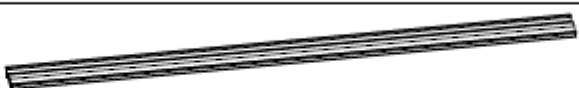
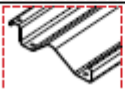



Cutia 4/4

REF	ICON	QTY
GO-1	 	1
GO	 	8

ASAMBLARE

1. Asamblarea lamelelor
2. Structura cadrului
3. Instalarea lamelelor și a conexiunilor

1. Asamblarea lamelelor

REF	ICON	QTY	REF	ICON	QTY
LO		18	MO		37
LO-1		19	UO	 lock nut	37
			XO	 6×35 4mm	37

REF	ICON	QTY
ZO-1	 4mm	1
ZO-2	 4mm	1
ZO-5	 10-12mm	1

*În ilustrație este utilizată o cheie manuală, care poate fi înlocuită cu un burghiu electric cu cap în cruce (P-tip).



Instalarea axurilor pentru capacele lamelelor pe ambele părți ale acestora.
Notă: Pentru a evita deteriorarea pieselor din plastic (MO), reduceți cuplul de torsiune la folosirea burghiului electric.

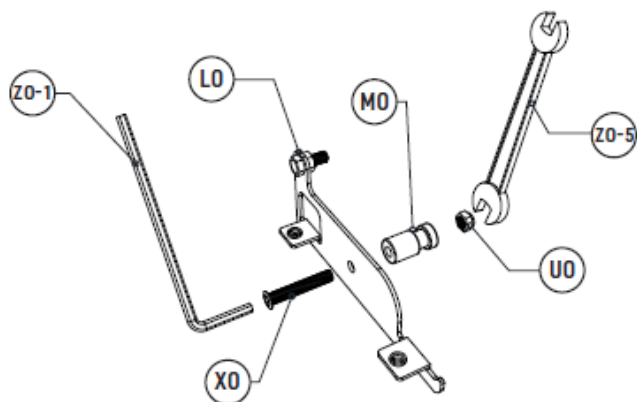

×18

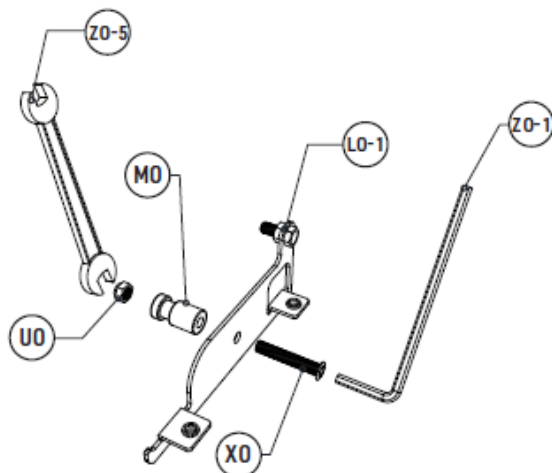

×19



REF	ICON	QTY
GO-1		1
GO		18

REF	ICON	QTY
KO		1
WO		76
SO-1		38

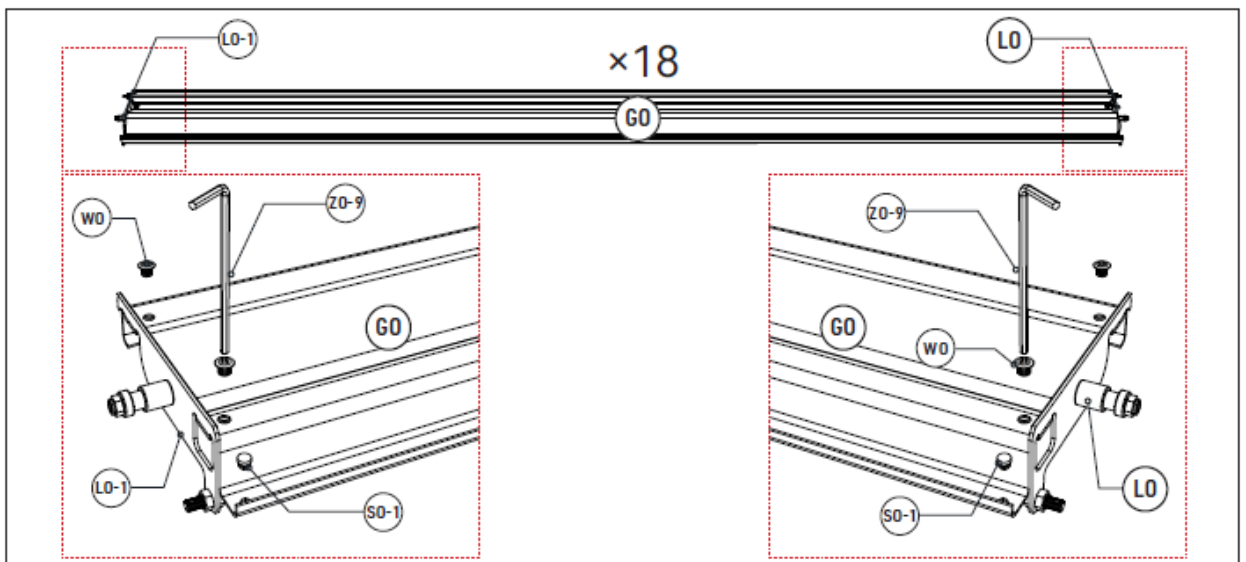
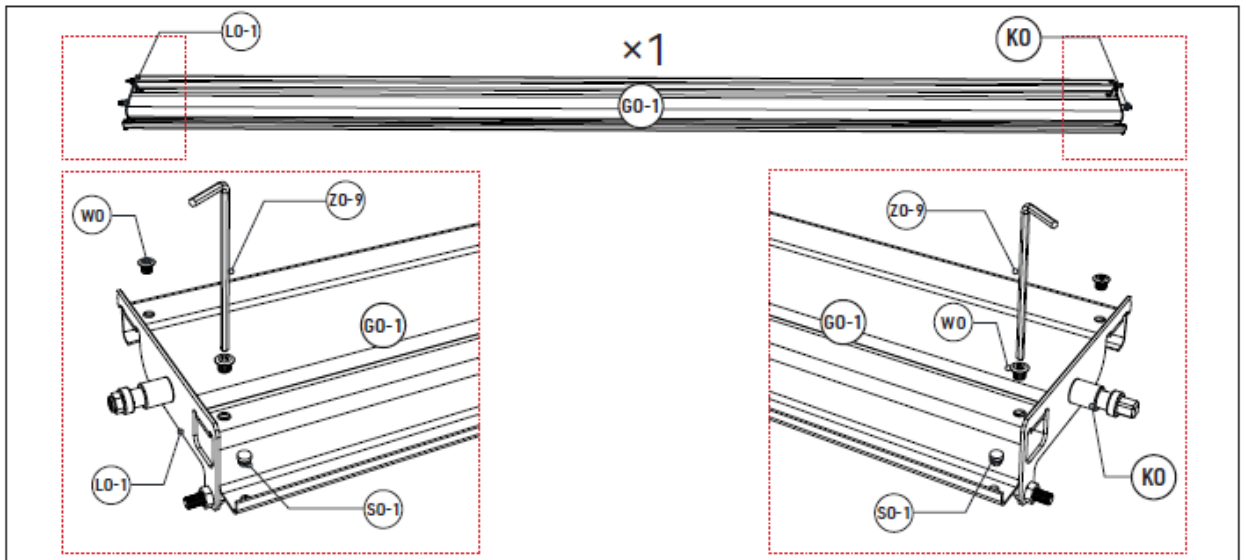

REF	ICON	QTY
ZO-9		1
ZO-10		1

Instalați capacul lamelelor pe ambele părți ale acestora și capacul axului pe ambele capete ale lamelelor deja montate.



2. Structura cadrului

REF	ICON	QTY
AO		4

REF	ICON	QTY
IO		4
JO		4
XO-1		16

REF	ICON	QTY
ZO-1		1
ZO-2		1

Instalarea fusteii pentru piciorul stâlpului:

- poziționați creștătura fusteii pe creștătura stâlpului.
- apoi montați placa de bază pentru fixarea pe suprafața inferioară a stâlpului.



REF	ICON	QTY
CO		2



REF	ICON	QTY
QO		8

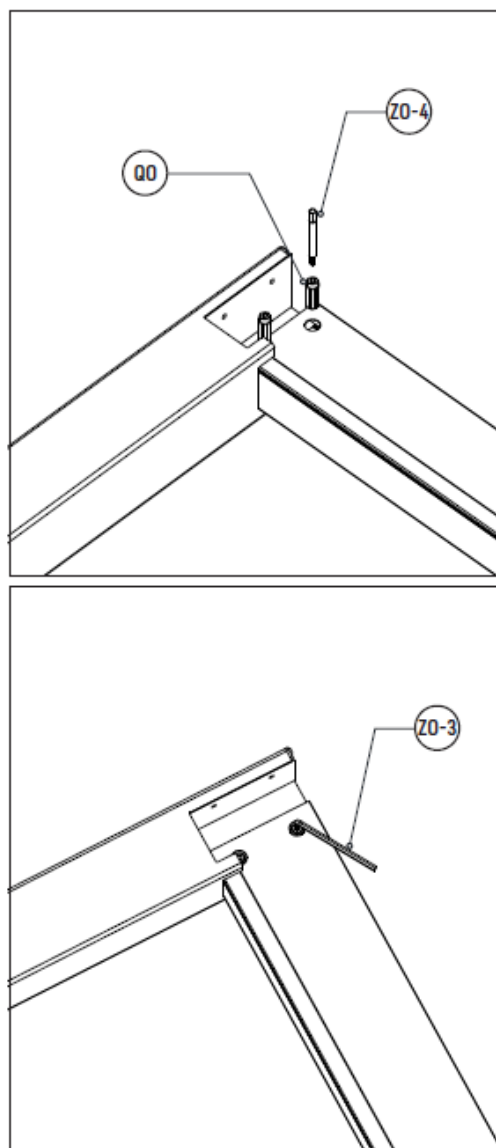
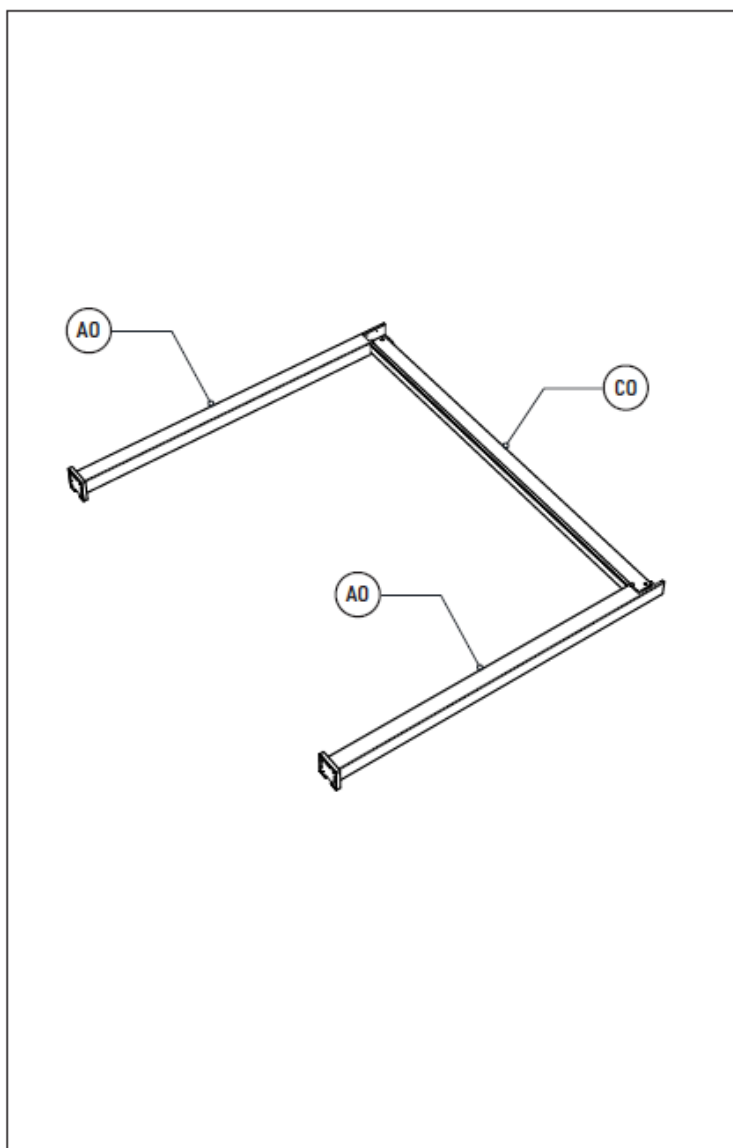

REF	ICON	QTY
ZO-3		1
ZO-4		1

Montarea grinzilor laterale:

- așezați stâlpii pe sol.
- finalizați instalarea grinzilor laterale.



REF	ICON	QTY
BO		1
BO-1		1

REF	ICON	QTY
QO	 	8

REF	ICON	QTY
ZO-3		1
ZO-4		1

Montarea grinzilor principale:

- ridicați grinzile laterale montate.
- instalați grinzile principale la fiecare capăt.

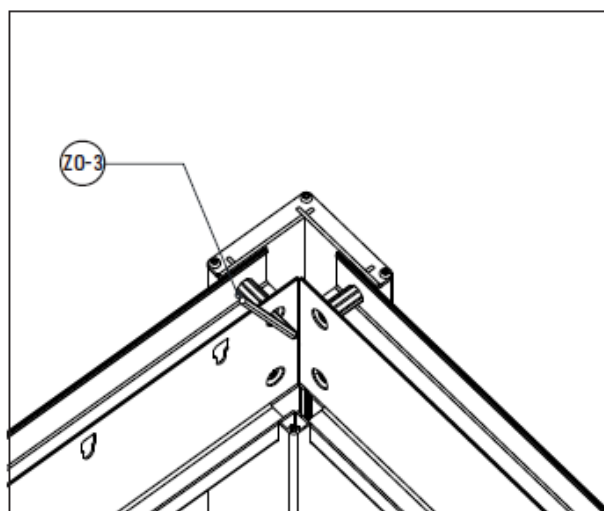
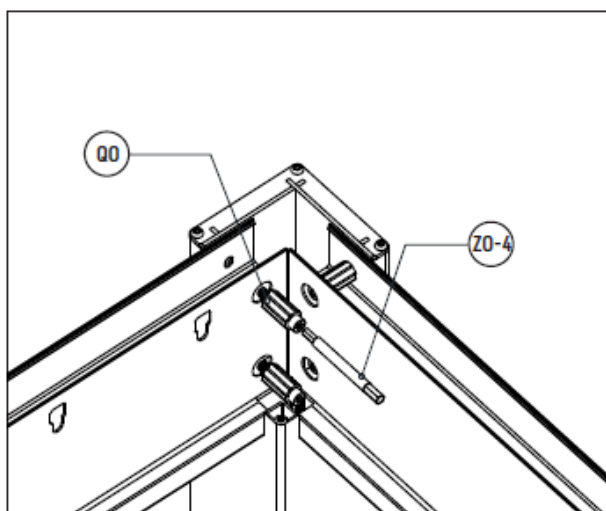
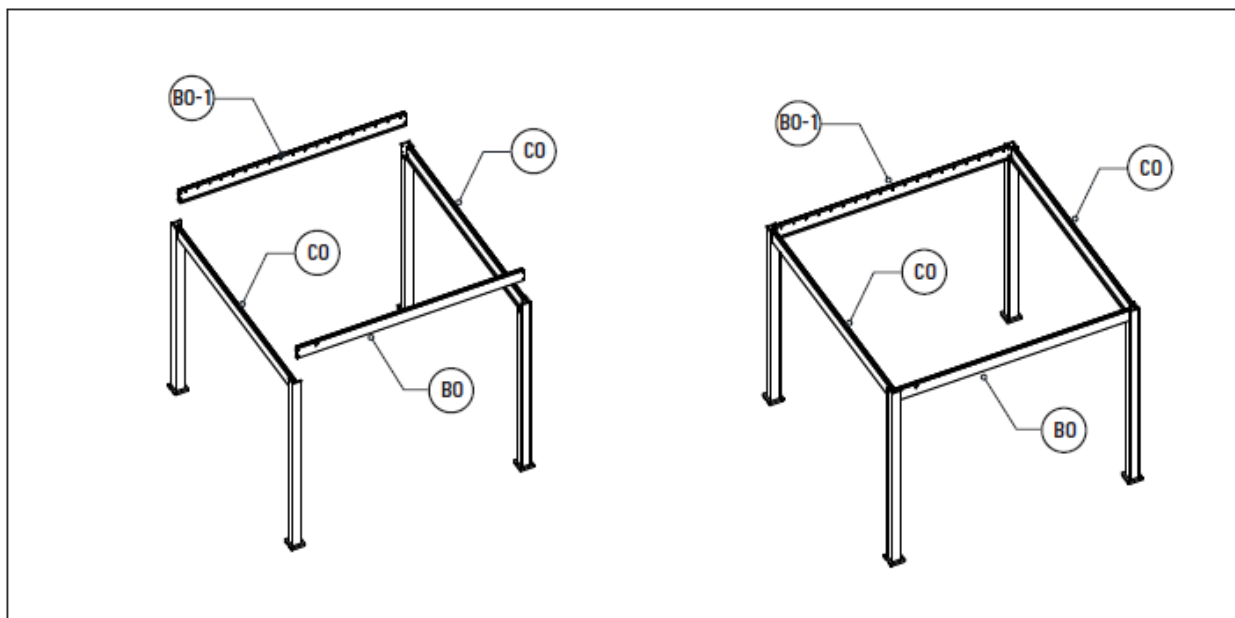



3. Instalarea lamelelor și a conexiunilor

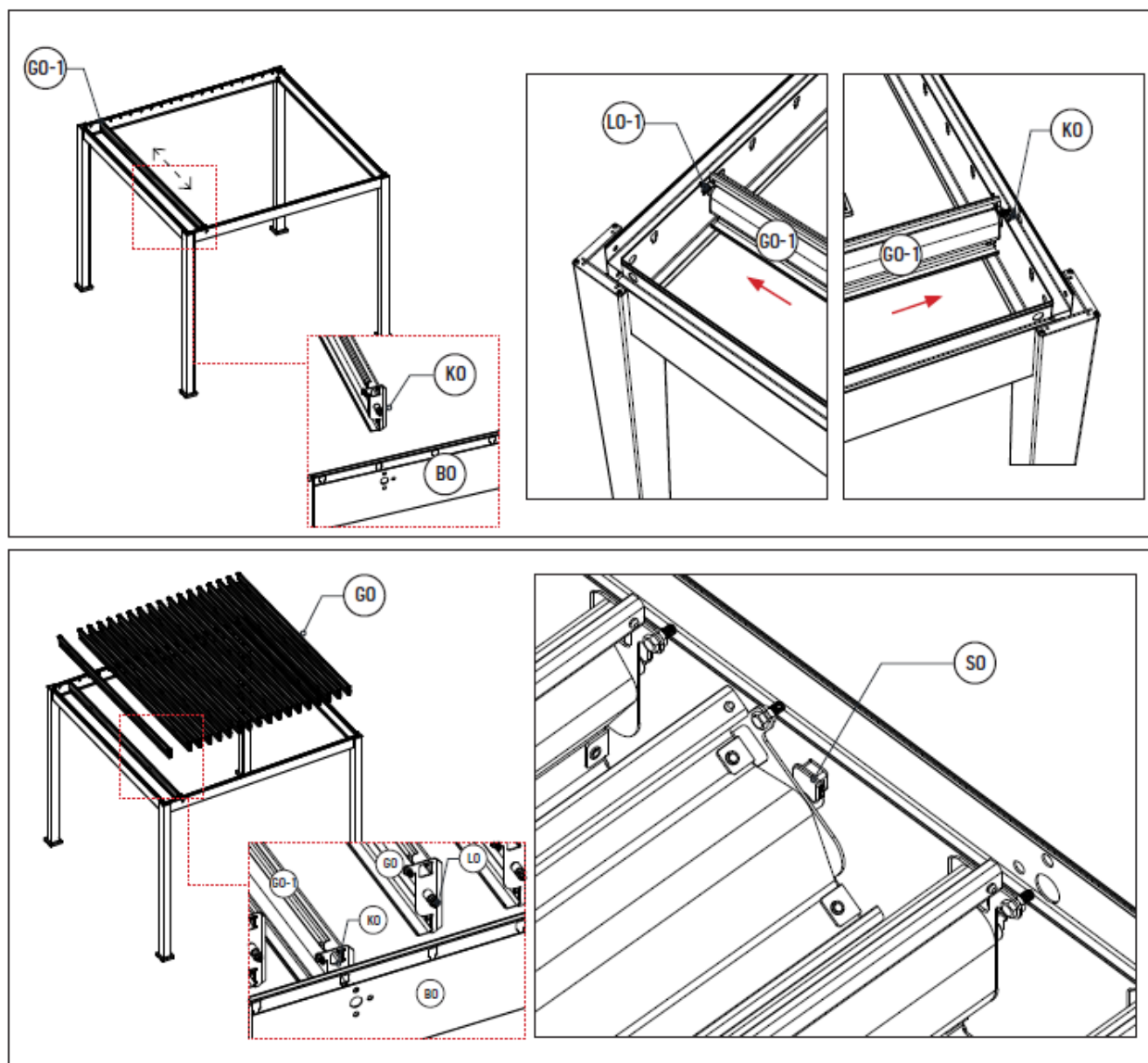

REF	ICON	QTY
SO		38

Instalarea lamelelor cu axuri:

- introduceți complet un capăt al lamelei în orificiul decupat din grindă.
- apoi fixați și celălalt capăt.



REF	ICON	QTY
HO		1

REF	ICON	QTY
NO		1
OO		1
PO		1
YO		3



REF	ICON	QTY
ZO-1		1
ZO-2		1

Instalarea angrenajului și carcasi:

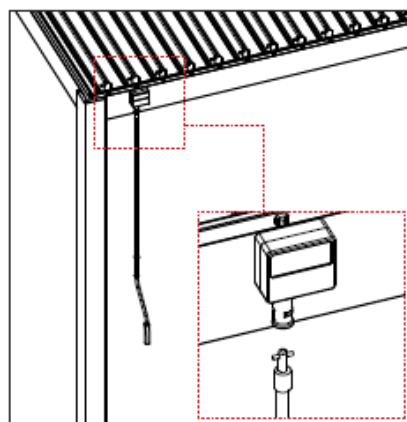
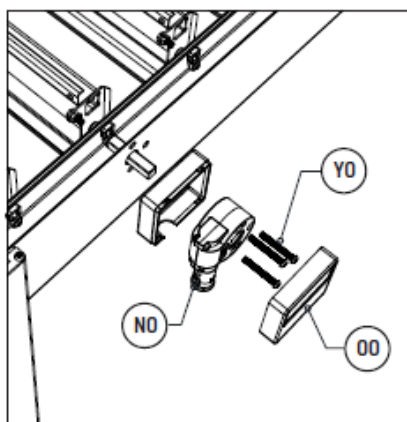
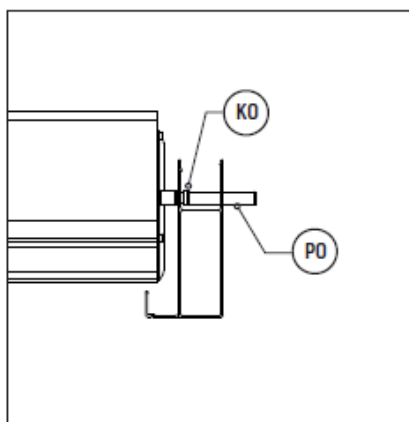
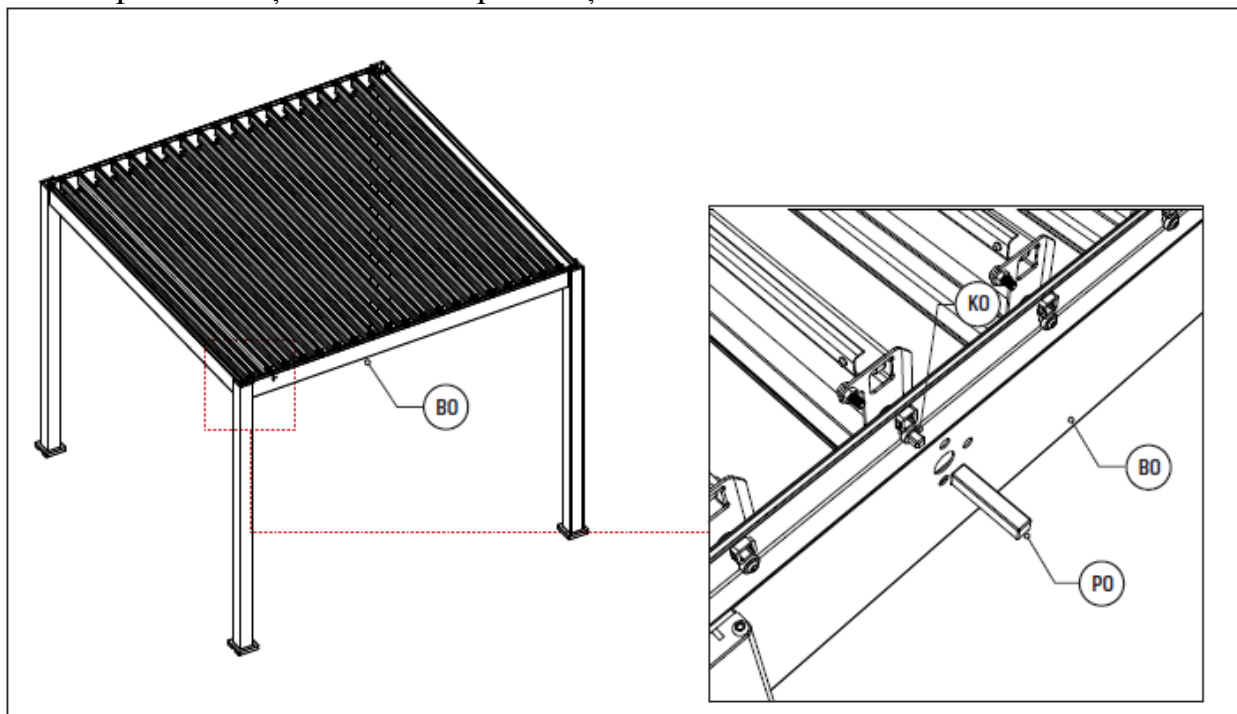
- localizați deschiderile din exteriorul grinzii principale.
- atașați găurile conectorului la ax.
- apoi instalați carcasa din plastic și cutia de viteze.





REF	ICON	QTY
FO		2

REF	ICON	QTY
UO	 lock nut	2
VO		2

Fixarea tijei de conectare:

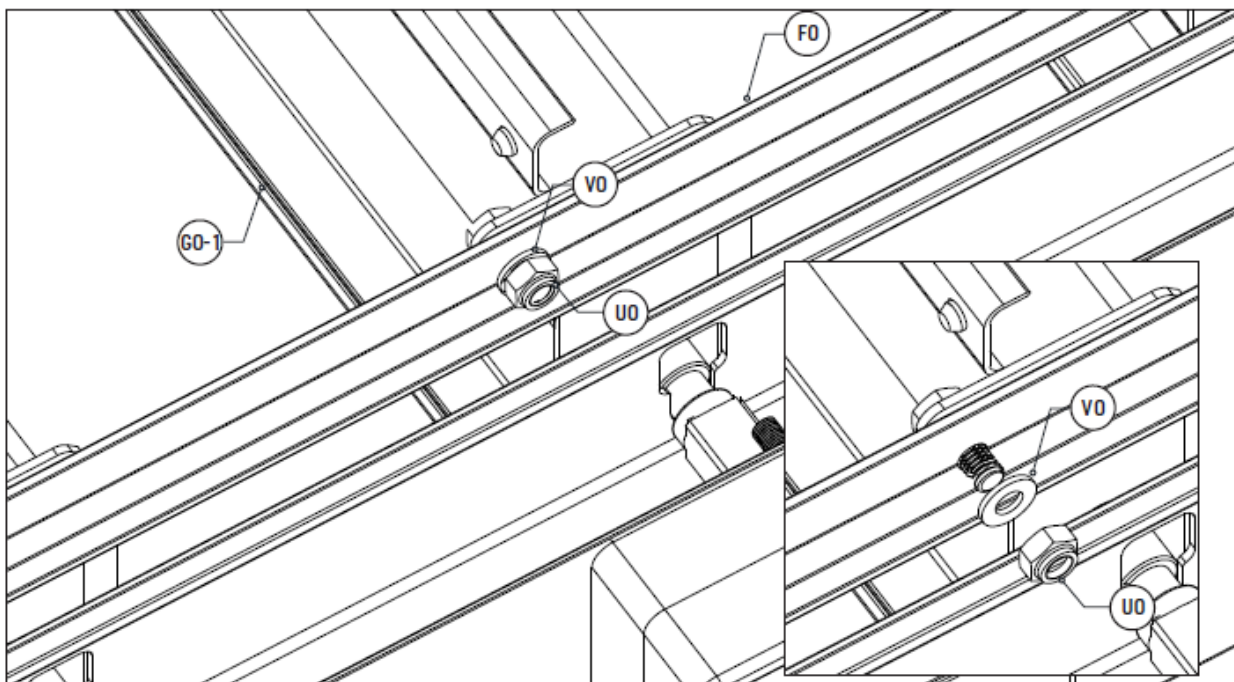
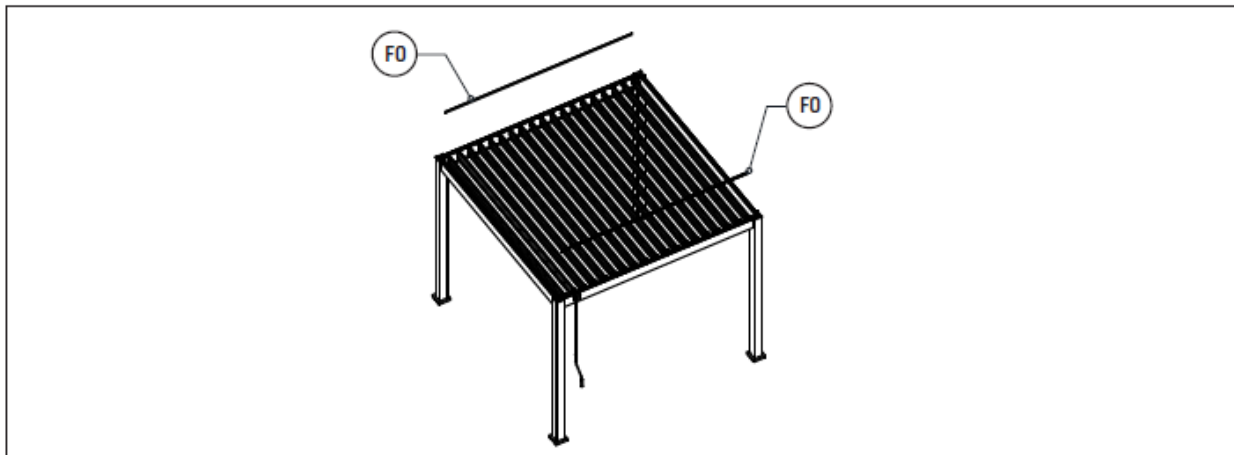
- ataşați tija de conectare pe lateralul axului lamelei.





REF	ICON	QTY
UO-2		36
UO-4		36

Continuarea fixării tijei de conectare:

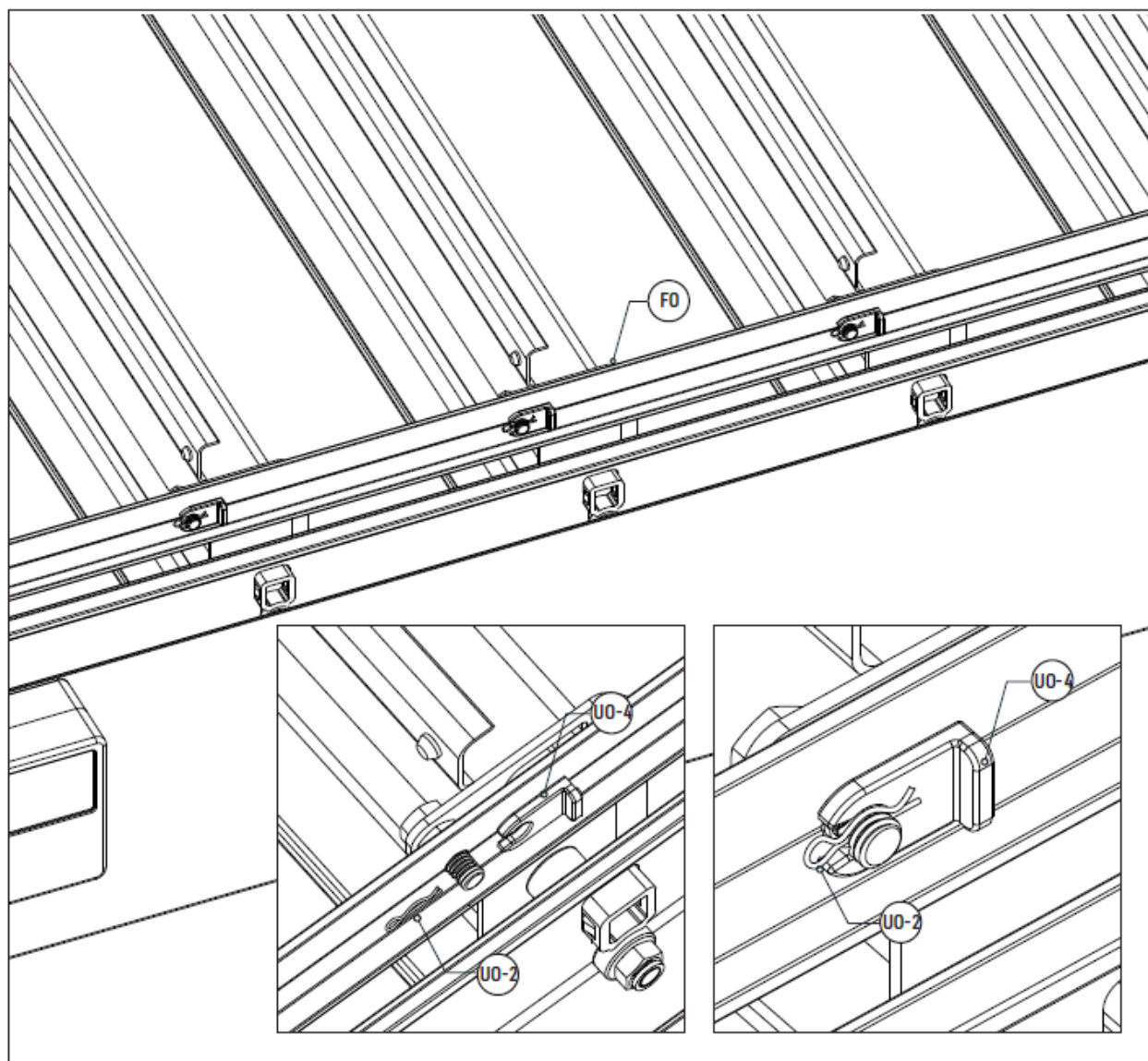
- folosiți piulițele și elementele de blocare pentru a fixa tija pe ambele părți.



REF	ICON	QTY
DO		4

REF	ICON	QTY
RO		16
TO	 10x80	16

Finalizarea montajului:

- capacele terminale: Montați capacele la capetele grinzilor.
- acoperirea găurilor șuruburilor: Utilizați capacele din plastic pentru a masca orificiile de prindere între grindă și coloană.
- fixarea pe fundație: Aliniați baza stâlpilor conform dimensiunilor din prima pagină. Folosiți un burghiu de 12 mm pentru găuri, introduceți diblurile de expansiune și strângeți-le cu o cheie M17.

